

SATURN S8

AUTOMATIC ROTARY RING STRETCH WRAPPER

MAXIMUM
CAPACITY

UP TO

160

pallets/hour



THE FASTEST
ONE

MOVITEC

WRAPPING TECHNOLOGY

we dare to try anything

- **MAXIMUM CAPACITY:** up to 160 pallets/hour.
- Maximum quality, high performance and minimum maintenance.
- Double unwinding head.
- The load remains static: the film reels rotate around the load.
- Guaranteed savings of stretch film: 300% film pre-stretching.
- 1m of film becomes 4 m.
- Finishing without tails of film thanks to our efficient cut and welding device.
- Electronic and self-adjusting tension control depending on the profile of the load.
- Possibility of applying efficient dustproof and rainproof wrappings.
- Possibility of wrapping at ground level.
- Capable of applying bands (strips) at any height of the load.

STANDARD EQUIPMENT

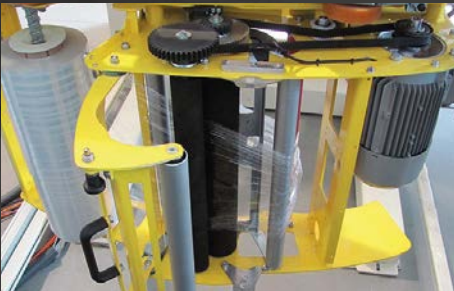

Quick-Load: Quick change of the reel



Touch panel

OPTIONALS



Top sheet dispenser



Independent top sheet dispenser



Motorized hold down plate

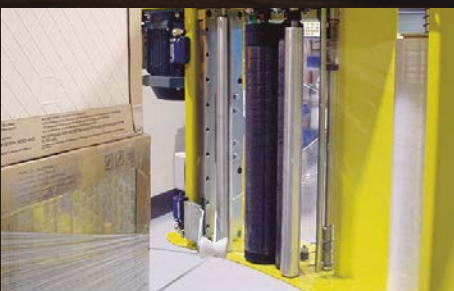

Roping device



ARC: Automatic Reel Change



EPS: Electronic Pre-stretch System

SATURN S8

MAXIMUM
CAPACITY

UP TO

160

pallets/hour



T3

SATURN S8

AUTOMATIC ROTATING RING STRETCH WRAPPING MACHINE



		D17	D20	D23	D26
PRODUCTION	Maximum capacity (p/h)	160	150	130	125
MACHINERY DIMENSIONS	A (mm)	7000		10000	
	B (mm)	2000		3000	
	C (mm)	3000		4000	
	D (mm)	2000		3000	
	E (mm)	3900	3900	4500	4900
	F (mm)	4200 *			
	G (mm)	2600 *			
	H (mm)	2300	2500	3150	3450
LOAD DIMENSIONS	Maximum width (mm)	1100	1300	1500	1800
	Maximum diagonal (mm)	1750	2050	2300	2600
	Maximum height (mm)	2100 (conveyors height 500 mm) *			
POWER SUPPLY	Voltage	400 V 3P + N + PE 50 Hz			
	Compressed air pressure (bar)	6			
STRETCH FILM	Maximum height (mm)	500			
	Maximum diameter (mm)	250			
	Inner core diameter (mm)	76			
	Film thickness (µ)	hasta 35			
TOP FILM	Maximum Height (mm)	1600	1800	2000	2400
	Maximum diameter (mm)	300			
	Inner core diameter (mm)	76			
	Film thickness (µ)	40			

* Possibility to adapt the frame of the machine for loads higher than 2100 mm

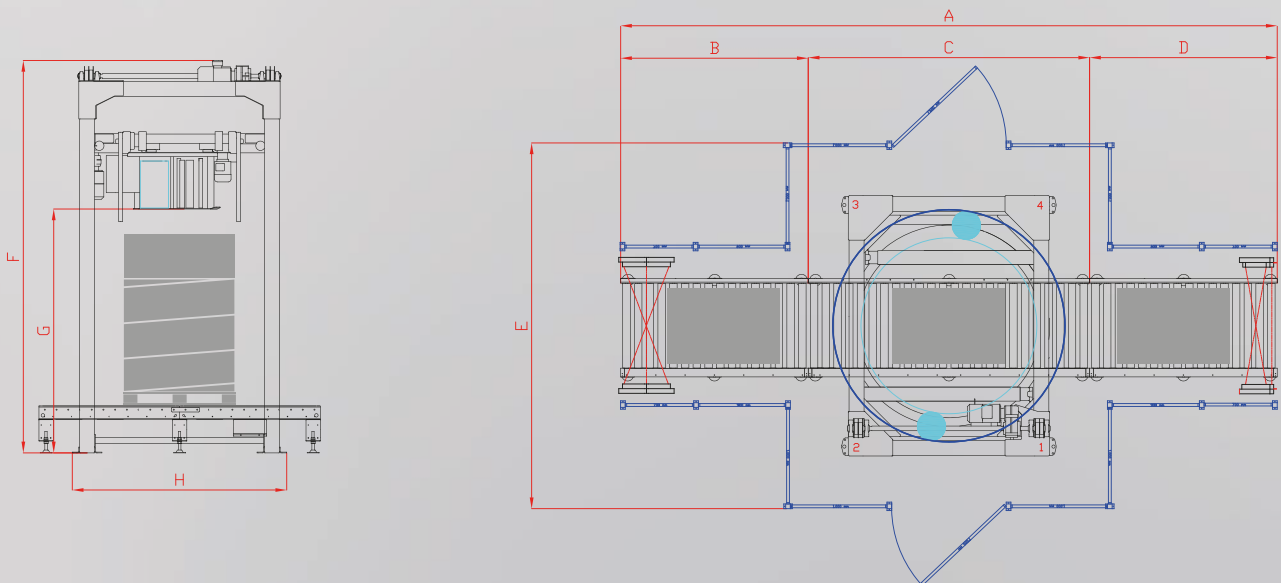

MOVITEC
WRAPPING TECHNOLOGY



www.movitec-ws.com

C. Pallars Sobirà, 16 · Pol. Industrial La Nora. 25660 · Alcoletge [Lleida] · SPAIN
Tel. [+34] 973 184 059 · Fax [+34] 973 184 008 · comercial@movitec-ws.com